

## Mounting instructions for electronic locks E4000 (version 5.2, as from 3.2001)

### Mounting the operating panel

Mount the operating panel control board to the level front panel of the safe door from outside. To do this, screw the two self-tapping raised cheese-head screws size M5 into the pre-drilled core holes  $\varnothing 4.5$  mm (see darkened areas) a few turns. Position the operating panel with its slide-catch slots onto the screws and shift it sideways. Secure the panel under the operation lever with the third screw joint M4. Seal the screw head with the plug-in type cap. Alternatively, on very thin doors, the operating panel can also be screwed-on using self-tapping screws at the four corners through the door mounting from inside. The separate earthing cable of the operating panel on the E6000 has to be connected to the frame potential of the safe.

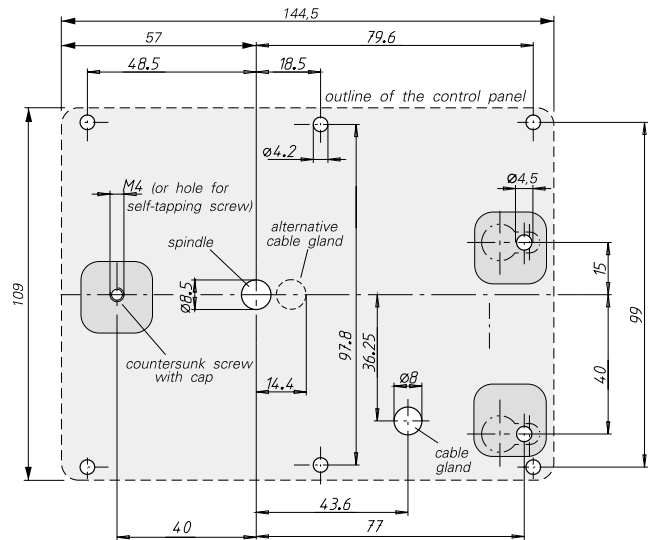

### Mounting the electromechanical lock module

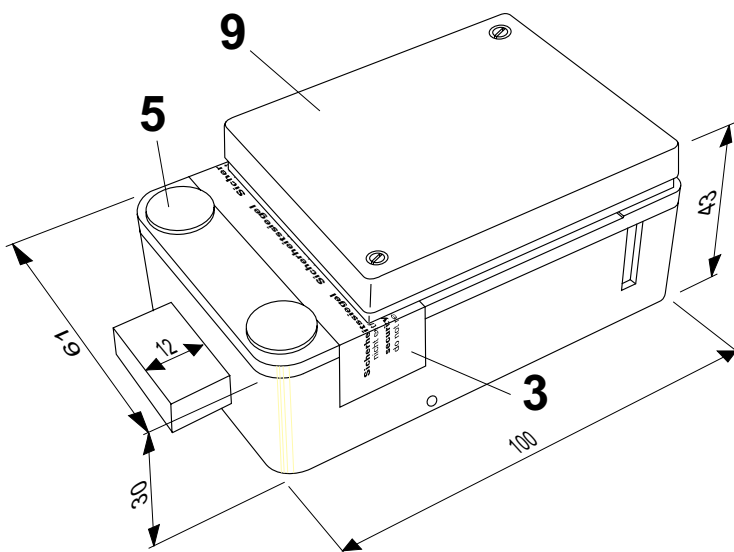

Although the module is suitable for mounting in any direction, it is important to observe the exact orientation of the axes of lock module and control board: the maximum lateral angular displacement of the drive shaft should not exceed  $2^\circ$ . The lock module is to be protected against direct or indirect access from outside by mounting adequately dimensioned armouring. There should be at least two layers of steel, each at least 3 mm thick, with a space in between, between the lock module and the outer surface of the door. Do not commence the installation unless you have taken the necessary precautions to stop foreign matter, dust or humidity entering the module. The electromechanical lock should never be oiled, greased or covered with paint.

Please note that the relative air humidity should not exceed 95% (non-condensing) for the lock to work correctly. This means that if there is a concrete wall adjoining the boltwork compartment, it must be dry before mounting the lock.

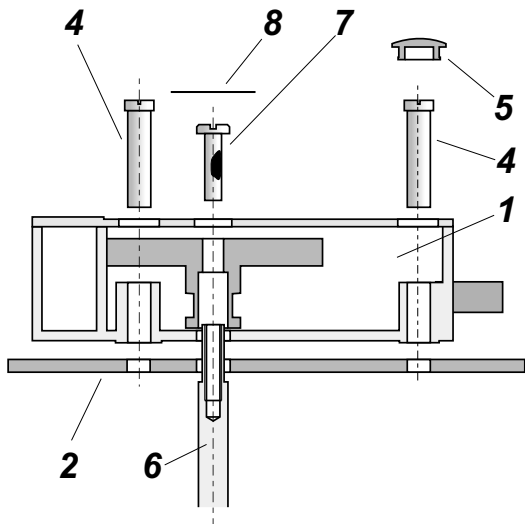

The lock module (1) is mounted on the level mounting surface (2) by means of the four screws (4) included in the supply. Enter the screws into the four holes in the lock module. To do this, there is no need to remove the lid, nor is this intended. We provided the sealing tape (3) to indicate this. Do not fasten the module with other screws than those supplied with the lock, because these have a special type of head. Screws with a different head shape could interfere with the lock performance. After screwing the lock module on, seal off the two through-holes in the lid by pressing plastic plugs (5) into the holes until they lock into place using finger pressure.

### **Mounting the lock shaft and the electronic board**

The purpose of the lock shaft (6) is to fasten the operating lever (20) on the outer operating panel (10) to the electromechanical lock module (1). If you did not specify the exact length required for your application at the time of ordering, reduce the shaft to the exact length as follows: Determine the wall thickness (T) of the safe door by measuring the distance between the two mounting surfaces (distance between outer surface operating panel and inner surface lock module) and adding 57.6 mm. The resulting figure is the total length to which the lock shaft has to be reduced (measure the shaft starting from the rounded end). Next, drill a  $\varnothing 33$  mm pin hole (6) 19 mm from the shaft end, assuring that the hole axis is perpendicular to the key faces of the shaft.

Now, join the lock shaft with the operating lever (20) by means of the enclosed locking pin (3 mm) supplied. For this purpose the operating lever has two intersecting boreholes in the fastening area: one for mounting the lock module in an upright position, the other for mounting it in a horizontal position. The joining operation completed, enter the lock shaft from the front into the bushing (15) until the key faces at the end of the shaft engage with the profiled hole inside the lock module.

Secure the lock shaft to the module with the supplied size M4 screw (7) as follows: Screw the screw from the lid end of the closed lock module into the shaft end until the axial clearance of the shaft approaches zero. The screw is supplied with a coating of thread locking adhesive to lock the screw in this position. Do NOT pull the screw tight as this would obstruct the mobility of the operating lever. Complete the assembly by attaching the supplied adhesive label (8) over the screw opening on the lid of the lock module to serve as dust guard. Now you can connect the cables to the electronic board and mount the board (9) on the backplate of the lockmodule.

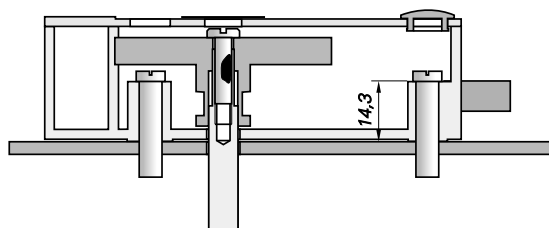
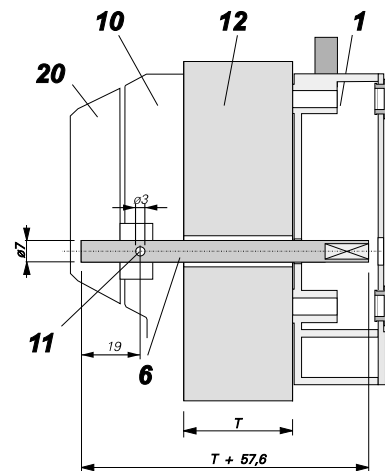

### **Bolt strength in accordance with VdS 2396**

Under normal conditions of use, the maximum permissible forces acting on the bolt in both directions (push and pull) amount to 5 N.

The illustration shows the maximum forces on the bolt (acting in the opening direction and at 90° angles from all sides) the impact of which will leave the lock with its locking functions impaired (resistance against forceful attack remains intact).

